

# Accounting for variation in Western Benue resultative verb constructions

Jakob Maché

Centro de Linguística da Universidade de Lisboa

`jakob.mache@ulisboa.pt`

Since the work by Lord (1975) and Déchaine (1993), it has been observed that Western-Benue languages fall into two groups as regards to resultative verb constructions (RVC): Whereas in languages as Yorùbá or Èdóid languages resultatives exhibit word order typical for serial verb constructions (SVC) NP<sub>subj</sub> V<sub>1</sub> NP<sub>obj</sub> V<sub>2</sub> (cf. 1), Ìgbò resultatives surface as compounds NP<sub>subj</sub> V<sub>1</sub> V<sub>2</sub> NP<sub>obj</sub> (cf. 2):

- (1) Òjè h́ó ńĺ ńkp̀n f́án.<sup>1</sup>  
 Òjè wash DET.S cloth be.clean  
 ‘Òjè washed the cloth clean.’ EMAI
- a. Òjè h́ó ńĺ ńkp̀n.  
 Òjè wash DET.S cloth  
 ‘Òjè washed the cloth.’
- b. ńĺ ńkp̀n f́án-ń.  
 DET.S cloth be.clean-FACT  
 ‘the cloth is clean.’
- (2) ń t̀-ń-ń ńkẃkẃ.<sup>2</sup>  
 3S throw-be.lost-rV paper  
 ‘He threw away the paper.’ ÌGBÒ
- a. ń t̀-ń-ń ńkẃkẃ.  
 3S throw-rV paper  
 ‘He threw the paper.’
- b. ńkẃkẃ f̀-ń.  
 paper be.lost-rV  
 ‘The paper got lost’

Apart from their diverging word orders, resultatives may differ across languages with respect to their verbal inflection. Emai and other Èdóid have a so-called factative suffix (-*ń* in Emai), which attach to past intransitive verbs and transitive verbs whose NP was fronted (cf. 1b). Whenever an intransitive verb is part of a resultative SVC (RSVC) it fails to bear the factative suffix (cf. Schaefer and Egbokhare 2017: 27–29, Ogie 2009: 83–103). In addition to the -*ń*-suffix, some Edoid languages have an rV suffix with a similar function, as shown by Yuka and Iyamu (2016: 1,1 9).

In contrast, Ìgbò has the factative -rV suffix, which attaches to all eventive verbs with past interpretation

and most stative verbs with present interpretation (cf. Nwachukwu 1984, Onukawa 1994, Mbah and Evelyn 2014). It consists of the sonorant [r] and a copy of the stem vowel of the verb to which it belongs (2a–2b). It does not occur with the copulas and small subclass of stative verbs in the present tense but, rather it would yield a past tense interpretation with these verbs. It also attaches to V<sub>2</sub> of resultative compounds and mirrors its stem vowel (cf. Nwachukwu 1984: 92–94, Emenanjo 2015: 457–459).

Despite all the variation discussed above, resultative verb constructions in Benue-Kwa languages are characterised by the features typical to serial verb constructions (SVCs), such as (i) shared value of polarity, (ii) shared value of TAM specification (cf. Stahlke 1970: 60, 78, 80, Baker 1989: 513, Déchaine 1993: 799–800, Collins 1997: 486, Aikhenvald 2006: 1, Aboh 2009: 3, Shluinsky 2017: 379). RVC are considered to be two-place predicates which typically involve an agentive subject referent selected by V<sub>1</sub> and a THEME which acts as the direct object of V<sub>1</sub> and the subject of V<sub>2</sub> at the same time (cf. Baker 1989: 529–532).

The aim of the study presented here is to provide an analysis which accounts for both the general characteristic of resultative verb constructions in Western Benue languages and the cross linguistic variation among them.

As shown by Lord (1975: 24–26) and Déchaine (1993: 807), there are two types of resultatives which differ with respect to the reference of the unrealised subject of V<sub>1</sub>: object oriented resultatives whose subjects referents for V<sub>1</sub> and V<sub>2</sub> have disjoint reference (eg. SUBJ<sub>1</sub>=Òjè and SUBJ<sub>2</sub>=‘cloth’ cf. ex. 1) and subject oriented resultatives whose subjects referents for V<sub>1</sub> and V<sub>2</sub> are co-referential. The study outlined here focuses on the object oriented type, which appears to be more complex. However, the analysis for subject oriented resultatives can be achieved with some minor tweaks

The first question which arises is how the shared noun phrase is adequately analysed. One challenge concerns the fact that the subject argument of V<sub>2</sub> is surfacing with object case. Most Benue language have developed case in their pronominal paradigm which distinguishes subject case, object case and possessor case (cf. Stahlke 1973: 192–193, Pulleyblank and Orié 2009: 874; Ogie 2009: 19, Schaefer and Egbokhare (2017: 236–237);

<sup>1</sup>Example from Emai taken from Schaefer and Egbokhare (2017: 698–701).

<sup>2</sup>Example from Ìgbò taken from Lord (1975: 24–25).

Atoyebi 2009: 170–184; Déchaine 1993: 812, Emenanjo 2015: 303–306, 358). As data from Yorùbá (3), Òkò Ìgbò (5) demonstrate, the THEME argument in RVC surfaces with object case, indicating it has a stronger link to the transitive  $V_1$  whose object it is, rather than to the  $V_2$  whose subject it is.

- (3) Ebí pa á/\*ó kú.<sup>3</sup>  
hunger kill 3S.O/3S.S die  
'Hunger killed him.' YORÙBÁ  
'He was extremely hungry.'
- (4) Àde tǎ-mọ ẹba falẹ.<sup>4</sup>  
Àde push-1S.O hand fall  
'Àde pushed me down.' ÒKÒ
- (5) ó rì-chà-rà yá/\*ó.<sup>5</sup>  
3S.S eat-be.finished-rV 3S.O/3S.S  
'He ate it up.' ÌGBÒ

Turning to standard GB/Minimalist approaches, it is not entirely clear how the unrealised subjects of  $V_2$  *kú* 'die' and *chà* 'be.ripe/finished' are to be analysed; There is no consensus whether they are traces of subject-to-object raising/AcI or object control with small pro (cf. Collins 1997: 482, 484–485, 494) or some entirely different operations (cf. Baker 1989: 529–532, Baker and Stewart 1999: 17–20; Déchaine 1993: 811–812). As there is no necessity in HPSG to postulate empty categories, it is assumed here that the relation between the unrealised subject of  $V_2$  and the coreferential realisation of the direct object of  $V_1$  are an instance of structure sharing: the THEME-NP is realised as object of  $V_1$  but being co-referential with the INDEX-value of the subject of  $V_2$ , as illustrated in Figure 1.

Following the spirit of Müller's (2002: 241, 2006: 873, 2013: 359) analysis, it is assumed here that RSVC are a result of applying a lexicon rule to a certain class of lexical full verbs which alters their valency by adding a resultative predicate to their COMPS-list, turning them into complex predicates which attract the subject argument of the unaccusative  $V_2$  and assigns object case to them. It is plausible to suppose that there is a more general type of this lexicon rule which holds across all Benue-Kwa languages, as the one sketched in Figure 1, which in turn is possibly only inherited by a universal rule. Each of the individual Benue-Kwa languages is considered to have more specified version, which contains language specific idiosyncrasies and which inherit the features they have in common from the general rule via an inheritance hierarchy, as exemplified in Figure 5 and 6.

The basic idea is that object oriented RVCs are *head-complements* or *head-cluster* structures, in which  $V_1$  is the syntactic head and  $V_2$  is its complement. This is illustrated by the fact that the overall RVC (6) inherits  $V_1$ 's

<sup>3</sup>Example provided by Olúwadára Omotòṣọ and Abídémi Jimoh.

<sup>4</sup>As quoted in Atoyebi 2009: 291–292.

<sup>5</sup>Example provided by Chinedu Uchéchukwu.

ability to form imperatives (6a), even if  $V_2$  cannot be used as imperative when it occurs alone (6b):

- (6) Jẹ ọbẹ ewédú tán!<sup>6</sup>  
eat soup jute.leaf be.finished  
'Finish up the ewédú!' YORÙBÁ
- a. Jẹ ọbẹ ewédú!  
eat soup jute.leaf  
'Eat the ewédú!' YORÙBÁ
- b. # tán!  
be.finished  
Intended: 'Be finished!' YORÙBÁ

Other arguments for considering  $V_1$  as the head are provided by Ogie (2009: 476–480) and Déchaine (1993: 806–807, 811–812). The general lexicon rule for Benue-Kwa languages determines the essential properties of RVC in these languages, as illustrated in Figure 1. Firstly, the COMPS-list of the overall RVC contains a shuffle operator, as proposed by Bender (2008), which connects the THEME-argument with the index  $j$  and the embedded unaccusative predicate. This shuffle operator allows to account for the word orders variation in among RVC in these languages either realised as  $NP_{\text{subj}} V_1 NP_{\text{obj}} V_2$  (Yorùbá or Emai type) or as  $NP_{\text{subj}} V_1 V_2 NP_{\text{obj}}$  (Ìgbò type). Secondly, this rule enables RVCs to attract the complements introduced by  $V_2$  (cf. [2]) into its own COMP-list. Thirdly, it accounts for the examples in Ìgbò discussed by Lord (1975: 33), in which the overall RVC can retain inherent (cognate) objects of  $V_1$  (cf. [1]). In its use as a simple verb, *lù* 'fight' always requires the presence of an cognate object *ọgù* 'fight', whose realisation remains mandatory even in RVCs (cf. 7).

- (7) Há lù-sò-rò ànyí ọgù.  
3P.S fight-against-rV 1P.O fight  
'They fought against us.' ÌGBÒ

Finally, this lexicon rule is capable of accounting for the well known fundamental properties of RVCs in Benue-Kwa, according to which all the verbal components share the same values polarity and TAM (cf. Stahlke 1970: 60, 78, 80, Baker 1989: 513, Aikhenvald 2006: 1, Bisang (2009) or Shluinsky 2017: 379). Bohnemeyer, Enfield, et al. (2007: 497, 502–508) and Bohnemeyer and Van Valin (2017: 144–148) argue that syntactic constructions differ with respect to whether or not they have the macro-event property (MEP). A construction  $C$  has the MEP if all its sub-events are always necessarily in the scope of time-positional adverbials such as *at 11:13 am*.

- (8) Macro-event property (MEP)  
A construction  $C$  that encodes a (Neo-) Davidsonian event description  $\exists e.P(e)$  ('There is an event  $e$  of type/property  $P$ ') has the MEP iff  $C$  has no

<sup>6</sup>The following examples provided by Olúwadára Omototo and Abídémi Jimoh.

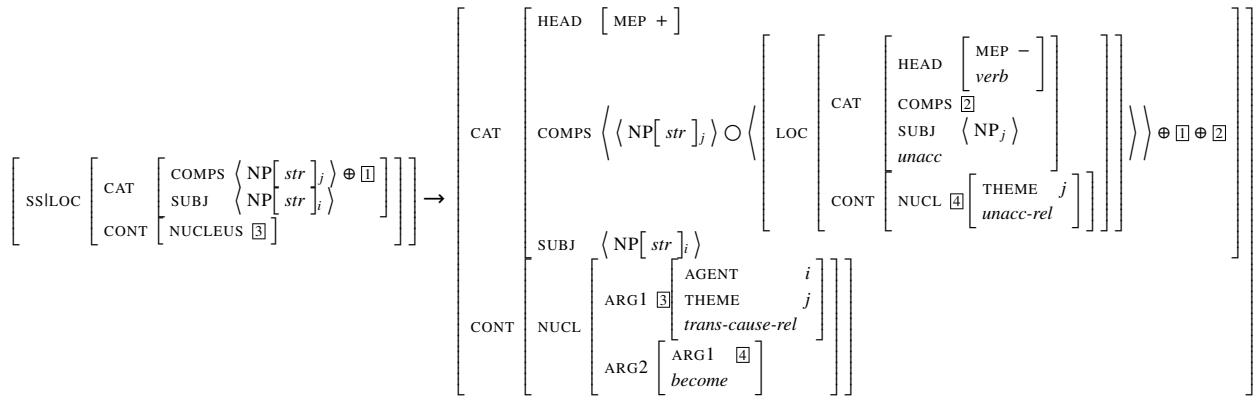

Figure 1: Lexicon rule for object oriented RVCs in Benue languages based on Müller (2002: 241–243, 2006: 873, 2013: 359)

constituent  $C'$  that describes a proper subevent  $e'$  of  $e$  such that  $C'$  is compatible with time-positional modifiers that locate the runtime of  $e'$ , but not that of the larger event  $e$ .

In their studies, Bohnemeyer, Enfield, et al. (2007: 506–507, 509–511) and Bohnemeyer and Van Valin (2017: 171–177) demonstrate that simple SVCs in Kwa languages have the MEP. Accordingly, RVC in Benue languages are considered here to exhibit the MEP, too. Thus the head of entire RVC must be specified as MEP+. In contrast, verbs which can be component of an SVCs have to be underspecified for the MEP: If they selected as component of an SVC they bear the feature MEP–, as they fail to be modified by time-positional adverbs. If they occur as a single main verb they exhibit the specification MEP+, in order to be able to be modified by time-positional adverbs. As it seems here, it is the distinctive property of languages which allow SVCs that (some) verbs can be specified as MEP–. Taking this into account, the lexicon rule can be modelled as follows: As the  $V_1$  in RVCs functions as the head of the overall construction and as it cannot be independently modified without the modifier taking scope over  $V_2$  too,  $V_1$  is specified for MEP+. In opposition, the component  $V_2$  itself does not constitute a macro-event, thus specified as MEP–, as shown in Figure 1.

Note that what is considered as a (macro)-event in a given language is not defined by a general objective ontology. Since each observable event can be decomposed into sub-events, it is impossible to define a repertoire of universally and cross-culturally accepted ‘atomic’ events. The event of eating for instance involves the movement of several muscles in the body and physiologically complex processes of digestion, which each can be split up into chemical reactions such as reorganising molecular structures et cetera. As proposed by Durie (1997: 322) and Aikhenvald (2006: 10–12), it differs from culture to culture what may be perceived as linguistically relevant (macro)-event.

In order to account for subject oriented RVCs, the lexicon rule is almost identical except for the CONTENT-value

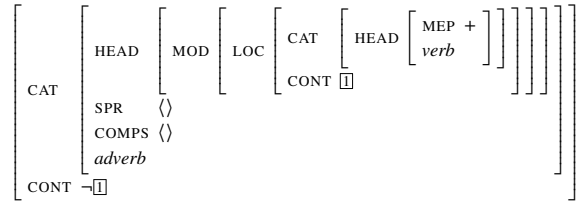

Figure 2: Lexicon entry for negation in Benue languages based on Müller (2020: 223) and Kim (2021: 817)

of the embedded  $V_2$ , in which the THEME-argument bears the index  $i$  referring to the AGENT-argument of the transitive or unergative  $V_1$  rather than the index  $j$ .

Returning to grammatical properties of SVCs, it was already mentioned that negation cannot scope over separate verbal SVC components, in a similar manner as time-positional modifiers. Thus negation is considered to be limited to modify verbal elements which are specified for MEP+, as illustrated in Figure 2. Given the negation’s selectional restrictions, it becomes evident why  $V_2$ , bearing the feature MEP–, cannot be independently negated. A parallel analysis can be assumed for the remaining TAM markers. In order to ensure that simple verbs outside RVC can be negated, they are considered to have the macro-event property, hence MEP+.

Note that NPs with structural case are independently necessary for Benue-Kwa languages to explain the fact that there are at least 50 verbal lexemes listed in Abraham’s (1958) dictionary for Yorùbá that involve a causative-inchoative alternation in which the THEME-argument can surface either as the direct object of the causative transitive variant or as the subject of the inchoative unaccusative variant. As Déchaine (1993: 807) following Awóbùlúyì (1971) pointed out, these verbs with alternation can even be the  $V_1$  in resultatives, such as the light verb use of *pa* ‘become.amalgated, get.in.contact’ (cf. Abraham 1958: 538), as illustrated in the examples (9a–9b) below:

- (9) a. Ó pa ìlẹ̀kùn yìí dé.  
3SG strike door this close



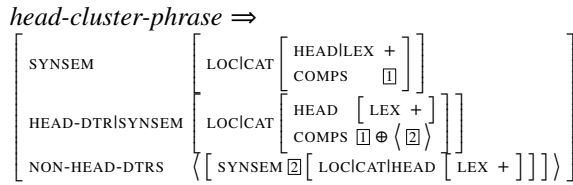

Figure 4: Modified ID-schema for head-cluster-phrase based on Müller (2002: 87, 347), Godard and Samvelian (2021: 443)

It should be noted that Godard and Samvelian (2021: 423) explicitly doubt whether Èdó SVCs like *sàán rrá* ‘jump cross’ are to be analysed as complex predicates. However, as illustrated in great detail by Déchaine (1993) and Ogie (2009) what is dubbed as SVC in literature on Benue-Kwa languages encompasses a wide array of syntactically fairly diverse constructions. As shown above, RVCs in these languages display beyond any doubt properties of complex predication such as: argument attraction, shared polarity and TAM values.

Finally, the variation in verbal inflection can be accommodated by language specific lexicon rules for the formation of resultatives, which inherits from the general lexicon rule 1. In both languages, it is assumed that the presence of the FACTATIVE or *rV*-suffix is modelled by a boolean HEAD feature. As shown by Schaefer and Egbokhare (2017: 27–29) for Emai, the factative *i*-suffix is only present with verbs which are not followed by a NP-complement. Such verbs would be marked with FACT+. In contrast,  $V_1$  and  $V_2$  in SVCs can never bear that suffix. This is achieved by the output of the lexicon rule for Emai illustrated in Figure 5: both the head  $V_1$  and the embedded  $V_2$  bear the feature FACT-.

In similar vein, Ìgbò has the boolean HEAD feature RV. As the *rV*-suffix always attaches to the last verbal element, the output of the lexicon rule sketched in Figure 6 yields a head  $V_1$  specified for RV- and a complement  $V_2$  specified for RV+.

Previous analyses in HPSG on related SVCs do either not explicitly address resultative SVCs and compounding (cf. Hellan, Beermann, and Andenes 2003), or they do not explain the variation in case assignment and the inflectional behaviour (cf. Ogie 2009: 476–480).

In contrast, most derivational approaches face serious challenges in providing an analysis for resultative SVCs, which forces the authors to make assumptions which contradict some of the core principles of these frameworks, such as head movement from an  $VP_2$  adjoined to  $VP_1$  to  $V_1$  (cf. Déchaine 1993: 811–812), double headed VPs (Baker 1989, Baker and Stewart 1999: 17–20), object control structures with small pro as phonologically empty subject (cf. Collins 1997: 482, 484–485, 494). Finally, Aboh (2009) can only account for SVCs in which the first verb is semantically bleached light verb.

## References

- Aboh, Enoch Oladé (2009). “Clause structure and verb series”. In: *Linguistic Inquiry* 40.1, pp. 1–33.
- Abraham, R. C. (1958). *Dictionary of Modern Yoruba*. London: University of London Press.
- Aikhenvald, Alexandra Y. (2006). “Serial verb constructions in typological perspective”. In: *Serial verb constructions*. Ed. by Alexandra Y. Aikhenvald and Robert M. W. Dixon. Oxford University Press, pp. 1–68.
- Atoyebi, Joseph Dele (2009). “A reference grammar of Òkọ”. PhD thesis. Universität Leipzig.
- Awóbùlúyì, Oladélé (1971). “Splitting verbs in Yorùbà”. In: *Actes du huitième congrès international de linguistique africaine, Abidjan 24–28 Mars 1969*. West African Linguistic Society, pp. 151–164.
- Baker, Mark C. (1989). “Object sharing and projection in serial verb constructions”. In: *Linguistic Inquiry* 20.4, pp. 513–553.
- Baker, Mark C. and Osamuyimen Thompson Stewart (1999). *On double-headedness and the anatomy of the clause*. Ms. Rutgers University.
- Bender, Emily M. (2008). “Radical Non-Configurationality without Shuffle Operators: An Analysis of Wambaya”. In: *Proceedings of the 15<sup>th</sup> International Conference on Head-Driven Phrase Structure Grammar, National Institute of Information and Communications Technology, Keihanna*. Ed. by Stefan Müller. Stanford, CA: CSLI Publications, pp. 6–24. URL: <http://csli-publications.stanford.edu/HPSG/2008/bender.pdf>.
- Bisang, Walter (2009). “Serial verb constructions”. In: *Language and Linguistics Compass* 3.3, pp. 792–814.
- Bohnenmeyer, Jürgen, Nicholas J. Enfield, et al. (2007). “Principles of event segmentation in language. The case of motion events”. In: *Language* 83.3, pp. 495–532.
- Bohnenmeyer, Jürgen and Robert D. Van Valin (June 2017). “The macro-event property and the layered structure of the clause”. In: *Studies in Language* 41.1, pp. 142–197. DOI: 10.1075/s1.41.1.05van. URL: <https://doi.org/10.1075%2Fs1.41.1.05van>.
- Collins, Chris Thad (1997). “Argument Sharing in Serial Verb Constructions”. In: *Linguistic Inquiry* 28.3, pp. 461–497.
- Déchaine, Rose-Marie A. (1993). “Serial verb constructions”. In: *Syntax: an international handbook*. Ed. by Joachim Jacobs. Berlin: De Gruyter, pp. 789–825.
- Durie, Mark (1997). “Grammatical structures in verb serialization”. In: *Complex predicates*. Ed. by Alex Alsina, Joan Bresnan, and Peter Sells. Stanford: Center for the Study of Language and Information, pp. 289–354.
- Emanajo, Nolue (2015). *A grammar of contemporary Igbo*. African Books Collective.
- Godard, Danièle and Pollet Samvelian (2021). “Complex predicates”. In: *Head-Driven Phrase Structure Grammar: The handbook*. Ed. by Stefan Müller et al. Empirically Oriented Theoretical Morphology and Syntax. Berlin: Language Science Press, pp. 419–488. DOI: 10.5281/zenodo.5599838.
- Hellan, Lars, Dorothee Beermann, and Eli Sætherø Andenes (2003). “Towards a typology of serial verb constructions in Akan”. In: *Proceedings of TROSS03 – Trondheim Summer School: Multi-verb-constructions*. Ed. by Dorothee Beermann and Lars Hellan. Institutt for språk- og kommunikasjonsstudier, Norges teknisk-naturvitenskapelige universitet.
- Hinrichs, Erhard W. and Tsuneko Nakazawa (1989). “Flipped out: AUX in German”. In: *Aspects of German VP structure*. Ed. by Erhard W. Hinrichs and Tsuneko Nakazawa. Sfs-Report-01-93. Tübingen: Eberhart Karls Universität Tübingen, pp. 13–23.
- (1994). “Partial-VP and Split-NP Topicalization in German – An HPSG Analysis”. In: *Partial-VP and Split-NP Topicalization in German an HPSG Analysis and its Implementation*. Ed. by Ewald W. Hinrichs, Tsuneko Nakazawa, and Walt Detmar Meurers. Vol. 58. Arbeitspapiere des SFB 340. Eberhart Karls Universität Tübingen.
- Kim, Jong-Bok (2021). “Negation”. In: *Head-Driven Phrase Structure Grammar: The handbook*. Ed. by Stefan Müller et al. Berlin: Language Science Press.
- Lord, Carol (1975). “Igbo compounds and the lexicon”. In: *Studies in African Linguistics* 6.1, pp. 23–48.
- Mbah, Boniface M. and Mbah Evelyn (2014). “RV Applicative in Igbo”. In: *Journal of West African Languages* 41.1, pp. 59–71.

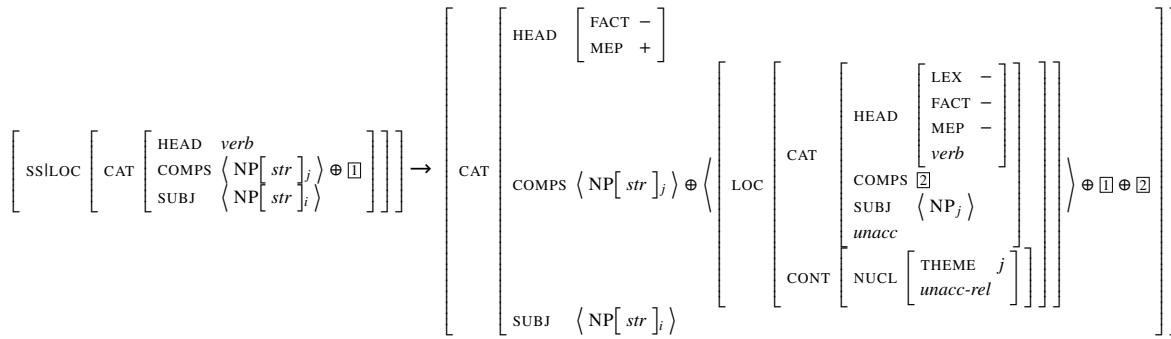

Figure 5: Language specific lexicon rule for RVC in Emai

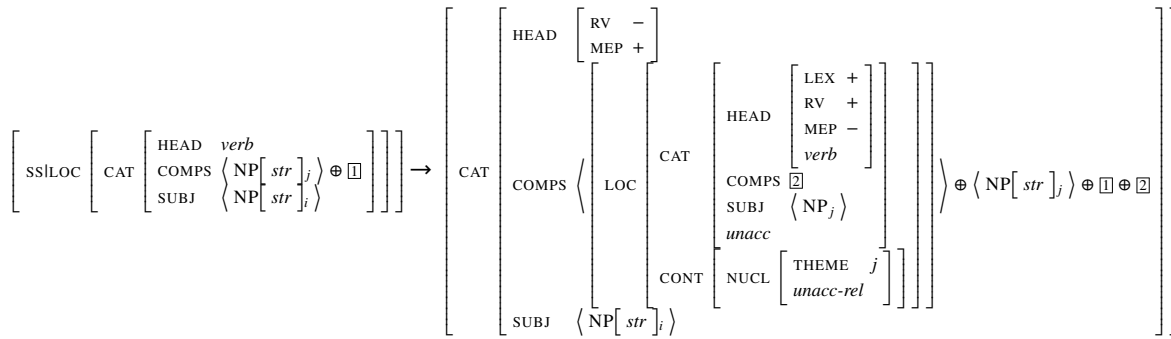

Figure 6: Language specific lexicon rule for RVC in Igbo

- Meurers, Walt Detmar (1999). "Raising spirits (and assigning them case)". In: *Groninger Arbeiten zur Germanistischen Linguistik (GAGL)* 43, pp. 173–226.
- Müller, Stefan (2002). *Complex predicates: verbal complexes, resultative constructions and particle verbs in German*. Stanford, CA: CSLI.
- (2006). "Discussion Note: Phrasal or Lexical Constructions?" In: *Language* 82.4, pp. 850–883. DOI: 10.1353/lan.2006.0213. URL: <https://doi.org/10.1353%2Flan.2006.0213>.
- (2013). *Head-Driven Phrase Structure Grammar. Eine Einführung*. 3rd ed. Vol. 17. Stauffenburg Einführungen. Tübingen: Stauffenburg.
- (2020). "German clause structure: And analysis with special consideration of so-called multiple frontings". To be published in *Language Science Press*.
- Nwachukwu, Akujūṣobi Philip (1984). "Stative verbs in Igbo syntax". In: *The Journal of West African Languages* 14.2, pp. 81–101. URL: <https://main.journalofwestafricanlanguages.org/index.php/downloads/summary/40-volumel402/177-stative-verbs-in-igbo-syntax>.
- Obiamalu, Greg Orji (2014). "Negation and V-movement in Igbo: a minimalist perspective". In: *SKASE Journal of Theoretical Linguistics* 11.2, pp. 42–58.
- Ogie, Ota (2009). "Multi-verb constructions in Èdó". PhD thesis. Trondheim: Norwegian University of Science and Technology.
- Onū̀kawa, M. C. (1994). "A reclassification of the Igbo = rV suffixes". In: *The Journal of West African Languages* 24.2, pp. 17–29.
- Przepiórkowski, Adam (1999). "On case assignment and 'adjuncts as complements'". In: *Lexical and constructional aspects of linguistic explanation*. Ed. by Gert Webelhuth, Jean-Pierre Koenig, and Andreas Kathol. Vol. 1. Studies in Constraint-Based Lexicalism. CSLI Publications, pp. 231–245.
- Pulleyblank, Douglas and Olanike Ola Orie (2009). "Yorùbá". In: *The World's Major Languages*. Ed. by Bernard Comrie. 2nd ed. London: Routledge, pp. 866–882.
- Schaefer, Ronald P. and Francis O. Egbokhare (2017). *A grammar of Emai*. Vol. 72. Mouton Grammar Library. De Gruyter Mouton.
- Shluinsky, Andrey (2017). "An intragenetic typology of Kwa serial verb constructions". In: *Linguistic Typology* 21.2, pp. 333–385.
- Stahlke, Herbert F. W. (1970). "Serial verbs". In: *Studies in African Linguistics* 1.
- (1973). "Ross' Constraints and related problems in Yorùbá". In: *Studies in the linguistic sciences* 3.1, pp. 192–230.
- Yuka, Lenzemo Constantine and Raphael Osarensen Iyamu (2016). "A unified analysis of the Èdo -LV suffix". In: *The Journal of West African Languages* 43.2, pp. 16–26.